



Pastomaster

60 RTX

The classic Carpigiani heat treatment equipment. Prepare base mixtures for Ice Cream, Gelato & Custard as well as prepare create gourmet specialties & syrups like pudding, chocolate syrup & more



Performance and Quality PASTOMASTER RTX machines mix, heat, age, and transfer frozen dessert mixes, keeping record of every step throughout each cycle. Create a uniform flavor profile in the entire liquid mix. It is capable of mixing up to 60 liters (16 gallons) of mix of mix per cycle. 16 programs for base mixtures and syrups and other liquid pastry products. 6 Frozen Dessert mixture programs. 3 Syrup Programs: Chocolate, Fruit & Zabaione. 5 Gourmet programs: Invert Sugar, Cream Syrup, Pudding, Panna Cotta & Bavarian Cream. 2 Yogurt programs: Liquid Yogurt, Thick Yogurt. 9 Personalized Programs.



Convenience Simple easy to read control panel. Transparent lid can be opened during production process since pump is located below.



Savings Prepare your own base mixtures and syrups from your choice of ingredients.



Safety Internal temperature is shown on screen. Exchange Pump uniformly heats or cools mixture for homogenization without burning any of the mixture. Memory retention during temporary power black-out. Refrigerated extraction spigot for maximum hygiene, and an exchange pump for low homogenization. Ergonomic design includes rounded corners to avoid injury. Optional stainless-steel drip tray is available.



Hygiene Built-in faucet with flex hose makes cleaning fast and easy. Optional Transfer mix set is available, ideal for transferring mixture equipment quickly and sanitarly with tube.



Pastomaster 60 RTX

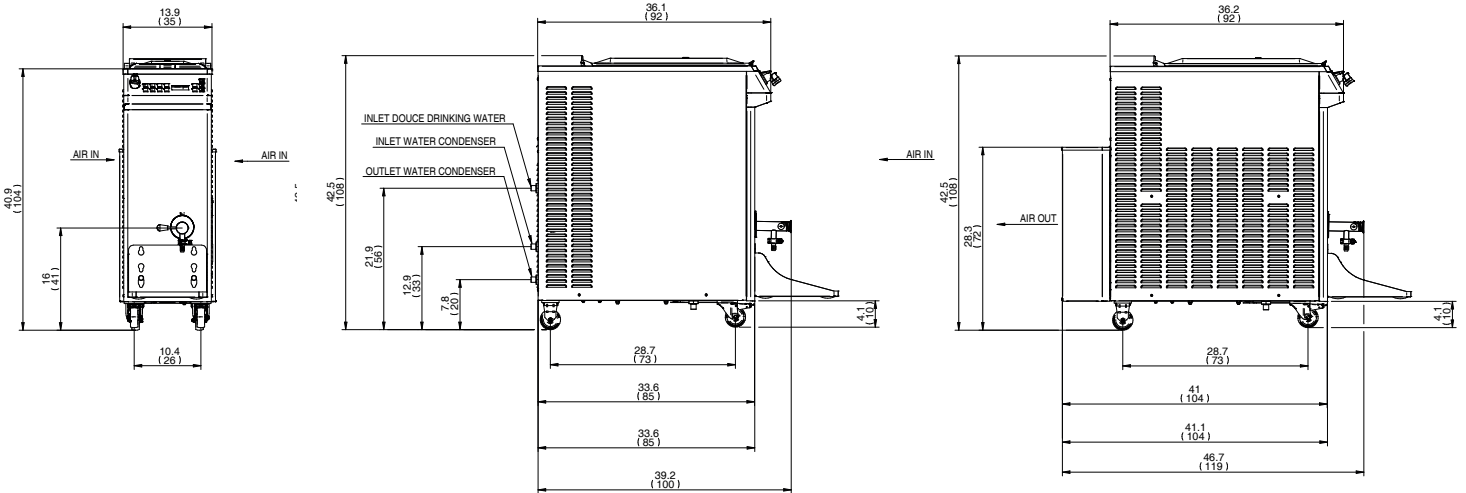

	WATER		AIR	
	lbs.	kgs.	lbs.	kgs.
Weights				
Net	357	162	357	162
Crated	407	185	462	210
	cu. ft.	cu. m.	cu. ft.	cu. m.
Volume	23.7	0.67	22.96	0.65
Dimensions	in.	cm.	in.	cm.
Width	13.9	35	15.2	39
Depth	47.6	121	54.1	137
Height	42.5	108	42.5	108
Electrical	Maximum Fuse Size	Minimum Circuit Ampacity	Poles (P) Wires (W)	
208-230/60/3 Water	25A	22A	3P, 3W	
208-230/60/3 Air	25A	22A	3P, 3W	

Specifications

Electrical

A dedicated electrical connection is required. Manufactured to be permanently connected. See the Electrical chart for the proper electrical requirements. Consult your local Carpigiani distributor for cord & receptacle specifications as local codes allow.

Refrigeration System

R404A

Water Cooled

Water inlets and drain connections in the rear 1/2" MPT

Air Cooled *

Minimum clearance: 6" (15 cm) on both side panels and 24" (60 cm) from the rear panel for proper air circulation.

Tank Capacity

63.4 quarts / 15.9 gallons (60 liters)

All specifications mentioned must be considered approximate; Carpigiani reserves the right to modify, without notice, all parts deemed necessary. This unit may be manufactured in other electrical characteristics and may have additional regulatory agency approvals, please consult the local Carpigiani Distributor. Check name plate for exact electrical data.

Bidding Specs									
Electrical	Volt	Hz	Ph	Neutral	Yes	No	Cooling	Air	Water
Options									



Distributed by:
GTI Designs
35 Trade Zone Court
Ronkonkoma, NY 11779

Tel: 800-896-4484
631-981-2100
CustomerService@gtidesigns.com
www.gtidesigns.com